

High Performance RFID for Rail Solutions



Every minute, thousands of reliable tag readings are made by TagMaster/Balogh equipment to enable safe, efficient and sustainable public transportation in major urban areas all over the world.

TagMaster



► On-Board Solutions

Typical applications, like CBTC, include determining the train’s position on the track. The reader’s accurate positioning capability is used for precise calibration of the automatic train control systems, enabling high throughput and accurate stop locations. Other on-board applications include selective door opening, PSD “Platform Screen Door”, wheelchair ramp control, automatic radio channel switching and automatic power switching in neutral zone passage and charging. Safety levels up to SIL4 can be supported.

CBTC

In Communication Based Train Control systems the traditional track-based interlocking and wayside train control is replaced by a continuous on-board positioning function and a continuous data exchange with the wayside infrastructure.

The reliability of the on-board train positioning system is vital for the trains to operate safely while still allowing a much higher throughput of trains than with traditional interlocking. This solution is also suitable for rubber wheel and mono/mag-rail systems. TagMaster/Balogh RFID systems have a proven track record; they are integrated into major CBTC systems available on the market today and have been operating for many years in major metro installations worldwide

London Underground, UK

4LM (Four Lines Modernization) Project in London Underground is one of the largest Metro signalling-upgrade projects in the world. Four of the busiest lines in central London are equipped with the Thales SelTrac CBTC system using TagMaster equipment for the positioning of the trains.

(Ref <https://tagmaster.com/wp-content/uploads/2016/04/Article-Railway-Gazette-april-2016.pdf>)



London Underground, UK

TRTC, Tawian

To provide accurate positioning to the Bombardier CITYFLO650 automatic train control system, TagMaster has supplied Heavy Duty readers for onboard mounting on the driverless rubber-tire light rail vehicle on the Neihu Line in Taipei.

The vehicle stops at an exact position to align with the station platform doors. The system also includes stationary track-side mounted readers for automatic identification of the passing vehicles.



Department of Rapid Transit Systems, Taiwan

The Purple Line, Thailand

The Purple Line in Bangkok is a good example of a recent installation where the TagMaster HD-Reader is used as an integrated part of the Bombardier Cityflo 650 CBTC signalling system.

The Purple Line in Bangkok was inaugurated in August 2016 and is expected to carry 200,000 passengers per day, increasing to 400,000 by 2019.



Purple Line, Bangkok, Thailand

When readers and beacons are face to face, a blue light turns on in the cab allowing final braking; automatic opening of WU doors is then triggered. This new automatic detection system guarantees correct operation, and its redundancy ensures a high system availability.

Platform Screen Doors

For the PSD Application - "Platform Screen Door", the Balogh Dialogue products support automatic and remote detection of the logical state - open/closed - of metro coach doors and the corresponding station platform screen doors.

Once the train is stopped and properly positioned opposite the platform screen doors, the driver or automatic system (in the case of driverless metros) controls the opening of the train doors.

The BALOGH MOS/OMS SIL 4 Safety Location solution allows automatic vehicle braking for precise positioning of the train opposite the PSD reference axis to within a few cm.

The status of the train doors is securely transmitted to the ground by the ERES 81 transmitter/receiver pair whereupon the ground control system then opens the screen doors, thus ensuring synchronization. When the train leaves, this procedure takes place in reverse.

Event triggering

Platform Detection - Train Accessibility for Wheelchairs

BALOGH Equipment is used to detect elevated station platforms for wheelchair access in the Bombardier application WU "Wheelchair User", developed as a part of the European RMU program "Reduced Mobility User".

This system automatically bridges the gap between the train and the elevated platform by using BALOGH RFID equipment for precise train positioning, thus providing safe wheelchair access.

The detection system of WU accessibility areas includes the following elements:

- BALOGH RFID readers on board the BOMBARDIER SPACIUM train
- BALOGH RFID beacons at the platform edge



Spacium WU Ramp, SNCF, France

▶ Tram and LRV Applications

Tram Signalling is different to other railway applications because the vehicles operate in an open environment together with all kinds of traffic: pedestrians, bicycles, cars, buses etc. Typical applications include accurate positioning of the vehicle, street crossing signalling and priority demand, speed limitation, selective door opening and passenger information systems.

Real-time information can be exchanged between on-board and track-mounted equipment. This two-way communication can be used to update the trackside signalling system of routing, destination ID, driver ID etc, or – when reversed – signalling status, speed control, switch status etc.

Priority Request at Intersections

Priority for trams over other road vehicles at intersections guarantees maximum safety for users while ensuring a high level of performance of the network. Safe operation is possible using synchronised traffic lights.

BALOGH DMOL detectors are installed onto the track. These detectors are connected to the traffic light controllers. For each direction of the tram line there is a priority request DMOL detector (which can be placed at a tram stop), a DMOL detector at the traffic lights and a DMOL Release detector, totalling 6 detectors per intersection (3 for each direction).

No manual action is required from the driver to make a priority request; the positions of the detectors are sufficient to both trigger and subsequently release the priority request.

Passenger Information Systems

The BALOGH RFID Reader MOL 81 is integrated into the AVLS "Automatic Vehicle Location System" within the Passenger Information System Application.



Visual panel in Paris metro displaying train position provided by MOL81/OMR equipment

Automatic Speed Control

Vehicle speed can be automatically regulated according to a control value provided by the infrastructure by way of the [ERES-ERES] transmitter/receiver solution which uses a two-way dialogue to exchange messages intermittently between the operations centre and the onboard automation system at a typical vehicle/track distance of 60 cm and at speeds of up to 200km/h.

A central computer calculates optimum speeds for different locations on the line and sends these to a network of track-side ERES beacons.

As the train passes over the track-side beacon, the on-board ERES receives the speed setpoint reference as well as location information via a secure communication exchange. The on-board ERES then sends this information to the train computer for processing.

Tram Way Command

The route commands are manually activated by the driver via a push button interface with the possibility of three commands: "straight", "right", "left". This information is sent to the on-board ERES 81 Transmitter / Receiver which transmits this command to the track-side ERES as the tram passes over it. The latter can then send this information to a local controller.

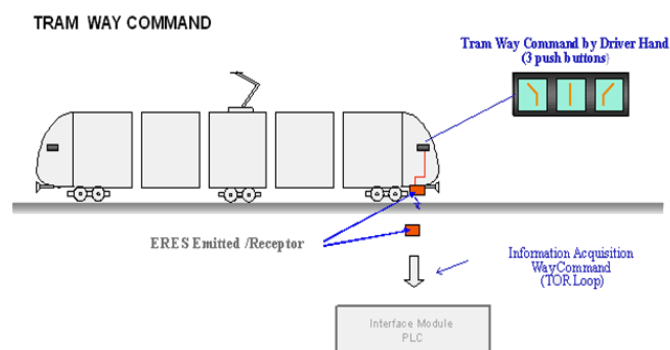

When the on-board / ground ERES pair are opposite each other, the digital logic levels applied to the inputs of one ERES are duplicated to the outputs of the other ERES and vice-versa.

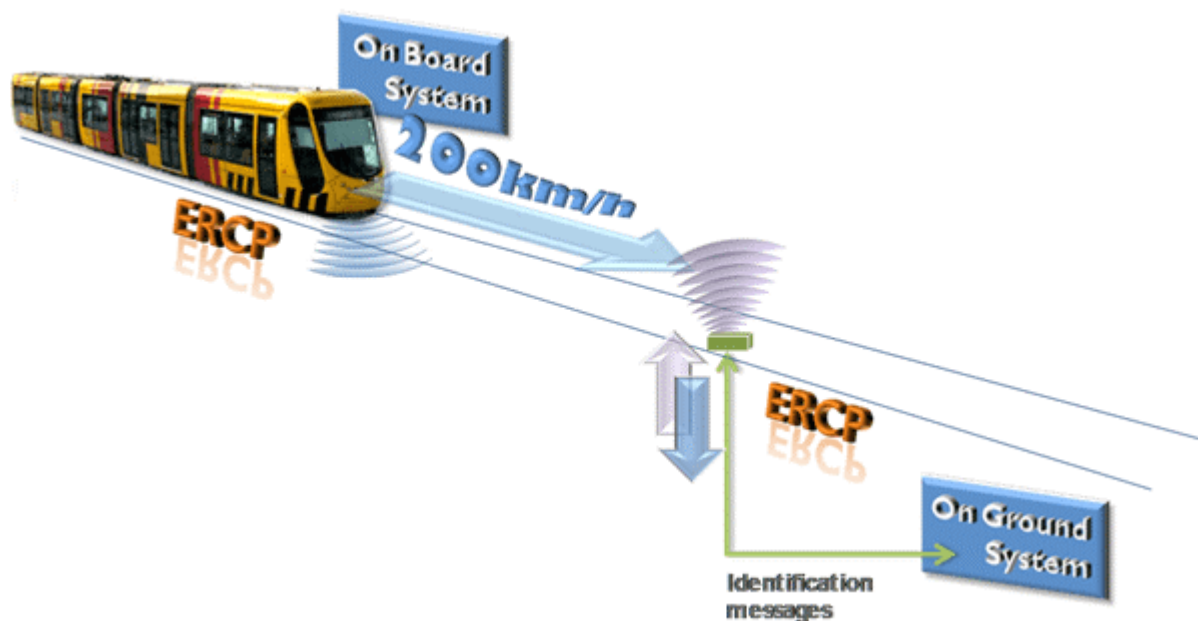

► Traffic and Condition Monitoring

TagMaster/Balogh monitoring solutions provide accurate and reliable information about train ID, passage time and direction of movement at defined locations. Vehicles without transponders can also be detected.

Automatic Vehicle Detection

In its simplest form it is a so-called AVI system (Automatic Vehicle Identification) where a track-side reader registers the passage of the vehicle and sends the tag data containing the unique vehicle ID to the supervising system. This information can then be used for various purposes such as statistics, billing, vehicle/load tracking, passenger information etc.

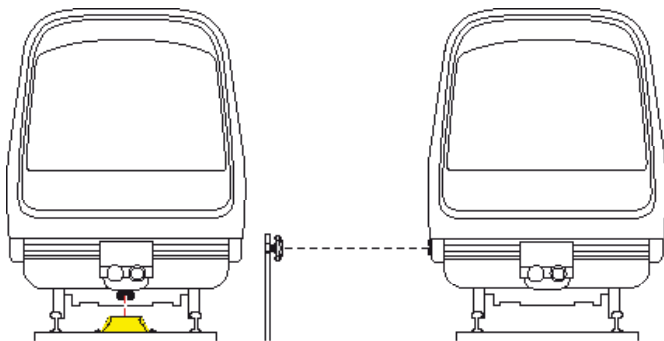

In this type of application the ID tag is mounted directly onto the vehicle and the RFID reader is mounted either on the side of the track or on the sleepers. This configuration is suitable for applications requiring the automatic identification or position of a passing train at full line speeds.

Condition Monitoring

For Condition Monitoring, AVI systems are often installed in combination with different sensor systems (for example wheel flats, brake failure, hot boxes, noise levels, tyre pressure etc) providing combined data from the measurement and the AVI function. The system provides accurate and reliable information about a train's location and the condition of the specific equipment detected at the location. This information is forwarded to track-side IT systems, where it is used to automatically update passenger information, train control systems and input for maintenance planning.

HOCHBAHN, Germany

TagMaster TrackReaders are used to detect vehicle ID and direction of the train movement in Hamburg Hochbahn. This information is used to monitor and optimize the operation and to display information for passengers.



HOCHBAHN, Germany

The Swedish Transport Administration Trafikverket, Sweden

TagMaster supplies Trafikverket (The Swedish Transport Administration) with long-range RAIN (EPC Gen2 /ISO 18000-63) compliant track-side UHF readers.

The Swedish Transport Administration has selected the TagMaster EPC Gen2 compliant UHF-Reader XT3-HD to be used for Automatic Vehicle Identification at strategic positions in the Swedish National Railway Network. At many sites, detected tag data from the XT3-HD reader is processed in combination with data from co-located sensor systems like Wheel Flat, Hot Box or weight detection to provide a straightforward reliable function.

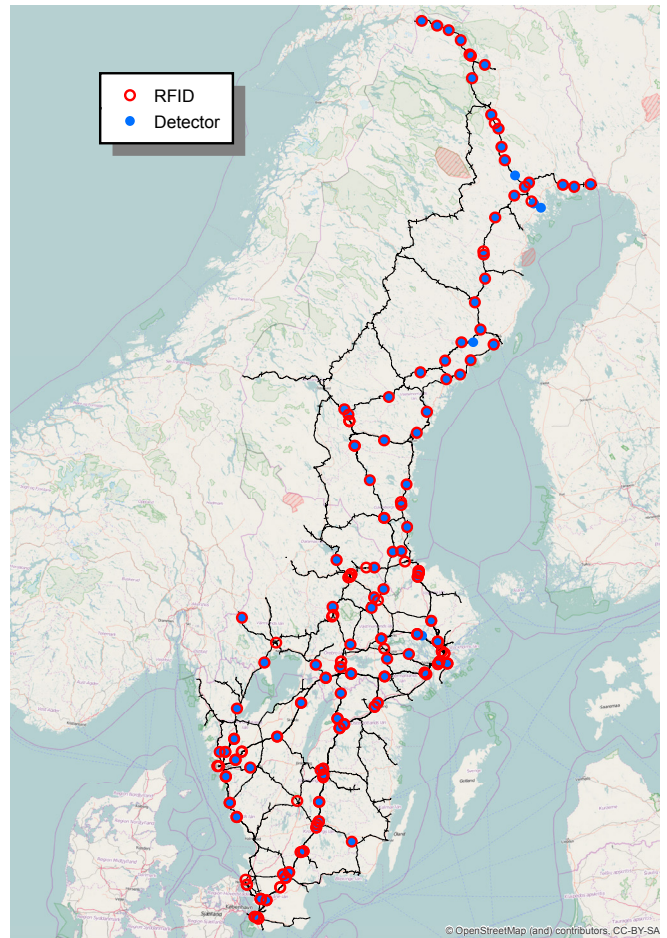

XT-3HD reader mounted track side, The Swedish Transport Administration, Sweden.

The Swedish Transport Administration installations of TagMaster equipment in Sweden

Dutch Railways, The Netherlands

In the Dutch Railways, TagMaster readers are used in combination with fibre optical sensors to detect wheel quality and axle load.



ProRail & NedTrain Services, The Netherlands

► TagMaster's RFID Technology

TagMaster has implemented a range of RFID products to suit the demanding identification applications found within the railway transportation sector. The TagMaster Heavy-duty (HD) product range includes several Readers and ID-Tags which utilise a number of RFID technologies and frequency bands.

The 2.45GHz, UHF and HF product series have varying characteristics which enable TagMaster to select the most favourable technology to suit both the customer's needs and the application's requirements.

In addition to CE and FCC certification, TagMaster tests and certifies the HD product range to stringent railway standards relating to temperature, vibration, shock and additional electrical and EMC tests.

TagMaster's 2.45GHz and UHF Readers are built around TagMaster's forth generation (GEN4) reader platform

which is based on a standard Linux operating system. GEN4 readers utilise TagMaster's open development platform, which enables both TagMaster and system integrators to quickly develop and implement new reader applications.

TagMaster provides a Software Development Kit that contains all the necessary tools required by system integrators to develop and test applications for GEN4 readers. The GEN4 Readers support several standard interfaces including Ethernet (TCP/IP), RS232 and RS485. These interfaces allow readers to be easily configured, for example via Ethernet using a standard web browser.

The following table summarises the key features and differences between TagMaster's different RFID technologies.

	2.45	UHF		HF
Air interface	Proprietary (TagMaster)	RAIN (EPC Gen2 /ISO 18000-63)		Proprietary (BALOGH)
Frequency	2.435 to 2.465 GHz	865.6–867.6 MHz Europe 902–928 MHz US, Americas		6.78 MHz, 13.56MHz
Frequency Usage	Globally approved	Regional variations		Regional variations
Reader locations	Track-side and Onboard	Track-side		Track-side and Onboard
Tag type	Semi-passive (BAP)* ¹	Passive		Passive
Passage speed* ²	400 km/h	200 km/h		200 km/h
Data integrity	32 bit CRC	16 bit CRC		16 bit CRC

Notes:

*¹ Battery Assisted Passive (BAP) i.e. contains a battery

*² Approximate passage speed, dependent on tag to reader separation

► Products for Rail Solutions

2.45



Heavy Duty ID-tag

The Heavy Duty ID-tags are mounted on the front, side, top or underneath each individual vehicle. They can also be mounted on the sleepers in special ID-tag fixings. The ID-tag

is extremely resistant, totally encapsulated and maintenance free. It has a predictable life of 10 years.



RailTag

RailTag is a 2.45 GHz heavy duty tag for rail applications. The tag is electrically programmable with up to 48 bits of user-defined data. The tag design and tag data retention supports 20 years life-time.

RailTag is vibration resistant, waterproof, UV stable and corrosion- and chemical resistant and fully supports APOS™, a reader function based on real-time signal processing for very accurate location of train position.



LR-6 HD

The LR-6HD reader is suitable for track-side installations. The readers can be installed at key locations such as stations, terminal entrances or maintenance centres.

The reader identifies ID-tags at a range of up to 10 metres and at passage speeds of up to 400 km/h.



Heavy Duty Reader

TagMaster Heavy Duty readers are designed to withstand environmental factors such as temperature, moisture, shock and vibration. This allows them to be mounted directly on the outside of vehicles.

This reader can be used to provide positioning information for onboard systems on a train.



Heavy Duty Track Reader

The HD Track Reader is specially designed to withstand the tough requirements of being directly mounted on the sleeper.

The unique built-in doppler radar can be used to determine the direction of a passing train, even in cases where the train is not equipped with an ID-tag.

► Products for Rail Solutions

UHF



XT-3 HD

The XT-3HD Reader is a fully functional RAIN (EPC Gen2 /ISO 18000-63) compliant UHF heavy duty RFID Reader with integrated antenna.



This reader is primarily intended for track-side installations in asset tracking applications within the railway industry where EPC Gen 2 UHF ID-Tags are mounted on passing trains or wagons.

HF



MOS 200

Compact & light HF solution appropriate for all vehicles: mass transit, metro, light rail, tram.

- Operating location accuracy : +/- 5 cm
- SIL 4 safety location accuracy : +/- 20 cm
- Reading distance: 60 mm up to 300 mm

- Data Exchange: 512 bits up to 160 km/h
- Reads OMS tags at 6.78 MHz
- Unaffected by climatic environments - water and ice
- Applications : CBTC, ATO, PSD



MOL 81

Short-range Reader (less than 0.8 meter) transmitting at 125kHz and receiving at 6.78 MHz.

The MOL 81 is a compact short-range transceiver, specially designed for railway applications (accurate train location, detection on crossroads, passenger information and depot management).

An all-in-one product with an integrated antenna, it will most often be used for on-board equipment which is placed on the outside under the mobile body, to read, "on the fly", the contents of the OMR-type RFID tags, placed along the track between the rails.



OMS 201

Read-Only reprogrammable electronic beacon

- Memory Capacity: up to 512 bits
- Static Memory Data
- No Battery
- Remote powering
- Fully sealed enclosure satisfying fire & smoke standards
- Protection rating IP 67

- General shock and vibration environmental conditions according to EN 50125-3
- Small size



OMR 81C

The OMR 81C identification tag can be read by the MOL81 and controlled or programmed by the LPP 1712-OMR81C portable Handheld device.

Reprogrammable read only electronic tag.

- Memory capacity: 144 bits(5x)
- No power supply, no battery
- 3 Digital inputs, selecting tag data register
- Remote reading
- Can be fixed either onto insulated support or metallic support
- General shock and vibration environmental conditions according to EN 50125-3

► Products for Rail Solutions

HF



OMR 201

The OMR 201 is a HF RFID Transponder/ Beacon/Tag read/detected by the MOL 81 Reader. The tag data is programmed by the programming tool LPP 1712 OMR.

- Memory capacity: 2 Bytes
- Passive, no battery
- Remote power (through air gap)
- Insensitive to severe weather conditions
- Railway standards



ERES 81

Transceiver for face-to-face contactless dialogue between train side & track side with additional digital inputs/outputs.

Short-range transceiver (less than 1 meter) operating at 13.56 MHz with 2 connectors: RS422 serial link + Digital 4 Input/ 5 output link.

Specially designed for railway applications - automatic Speed Control, train location data, switching command transmission, detection at crossroads, passenger information, depot management.



DMOL 81

The DMOL is a 125 kHz frequency detector, used in railway applications with the MOL 81 Reader. It activates a P-type digital output when detecting the presence of a MOL 81 in the vicinity.

- Detection zone length: 1.5 m
- Response time: 20 ms
- On-line autodiagnosics
- Insensitive to severe weather conditions
- Railway standards





Innovating smart technology, worldwide for Smart Cities

As more and more people move towards urban areas, cities worldwide are growing at a rapid rate. All over the world, the Smart City concept is bringing together technology with people to improve and simplify daily life. A Smart City uses intelligent solutions to optimise mobility and communication, creating safer societies with smoother traffic flows and more sustainable urban environments.

And that's where TagMaster comes in.

► Company Overview

TagMaster is an application driven technology company that designs and markets advanced identification systems and solutions based on radio & vision technology (RFID & ANPR) for demanding environments. Business areas include Traffic Solutions and Rail Solutions providing innovative mobility solutions, sold under the brands TagMaster, CitySync, Balogh and CA Traffic, in order to increase efficiency, security, convenience and to decrease environmental impact within Smart Cities.

Founded in 1994, TagMaster has a head office in Stockholm as well as dedicated agencies in the US and China. We export mainly to Europe, the Middle East, Asia and North America via a global network of partners, systems integrators and distributors.

For more information visit our web site at www.tagmaster.com



Kronborgsgränd 11
S-164 46 Kista, Sweden
Tel: +46 8 632 1950

Email: sales@tagmaster.com
www.tagmaster.com

28-32 Av. Anatole France
92110 Clichy, France
Tel: + 33 1 44 65 65 00

Email: contact@balogh-rfid.com
www.tagmaster.com